



# LASER MARKING SYSTEMS

Product Group Guide



# Datalogic at a glance

**Datalogic Group** is a global leader in the **automatic data capture and industrial automation** markets. It is well known around the world for designing and producing barcode readers, mobile computers, sensors for detection, measurement and safety, RFID, machine vision and laser marking systems. Datalogic solutions help customers increase the quality of their processes in the **Retail, Manufacturing, Transportation & Logistics**, and **Healthcare** industries.

The Group has **more than 50 years of history** behind it, during which enormous successes have been achieved: **10 R&D centers and 3 DL Labs in Italy, USA, Vietnam, and Czech Republic; 10 manufacturing and repair facilities** in USA, Hungary, Slovakia, Italy, China and Vietnam; a **portfolio of about 1,200 patents and patent applications** in multiple jurisdictions; thousands of prestigious partners and customers spread across five continents.

Datalogic Group has **offices in 27 countries worldwide**, with the headquarters in Bologna, Italy. It is through the close cooperation of **approximately 2,700 employees** that Datalogic can boast some of the most remarkable automatic data capture and factory automation solutions available today in the market.

## DATALOGIC TARGET INDUSTRIES



RETAIL

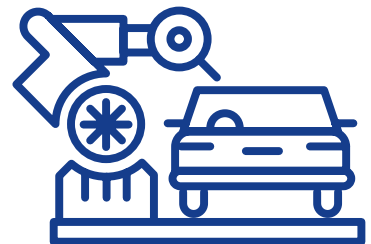

MANUFACTURING



TRANSPORTATION  
& LOGISTICS

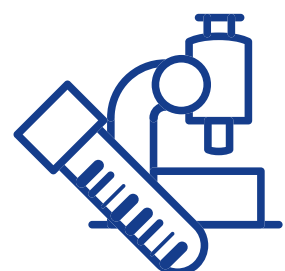

HEALTHCARE

# DATALOGIC PRODUCT RANGE



**Fixed Retail Scanners**



**Handheld Scanners**

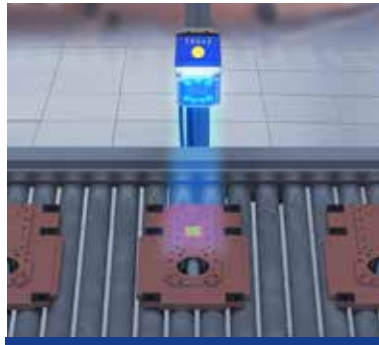

**Stationary Industrial Scanners**



**Mobile Computers**

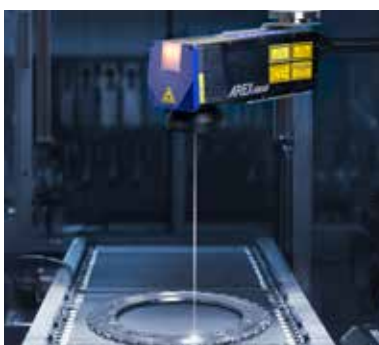

**Laser Marking Systems**



**OEM Barcode Readers**



**RFID Systems**



**Sensors & Safety**

by **DATASENSING**



**Machine Vision**

by **DATASENSING**



## CUSTOMER SERVICE

Datalogic's Customer Service offers a wide and complete range of post-sales services. It is organized in three levels of support, in order to guarantee the most appropriate professional assistance based on the specific problem. Datalogic's Customer Service can deploy in each territory a team of multi-lingual professionals, with a broad technical expertise across the whole product range.

Our standard service portfolio includes: warranty extension, fast turnaround time for repairs, 24/7/365 phone support, next day on-site intervention and site audits. Datalogic can tailor the service offering to your specific needs. Our experts will support every stage of your projects, from feasibility study to extended post-sales support, performing, when necessary, root cause analysis and remediation.



## EASEOFCARE Service Programs

Datalogic's EASEOFCARE Service Programs provide superior life-cycle support to ensure that products are always operating at peak performance. A variety of Service Programs are available to match your business requirements:



**FAST REPAIR TURNAROUND  
(OVERNIGHT/2 DAYS)**



**ACCIDENTAL DAMAGE  
COVERAGE**



**BOTH WAYS FREIGHT PAID  
BY DATALOGIC**



**DATALOGIC SHIELD  
FOR MOBILE PRODUCTS  
INCLUDED**



**3-5 YEARS CONTRACT  
SERVICE OPTIONS**

Please contact your sales representative to find out what type of services are available in your region.

[www.datalogic.com](http://www.datalogic.com)

# Laser Marking Systems overview

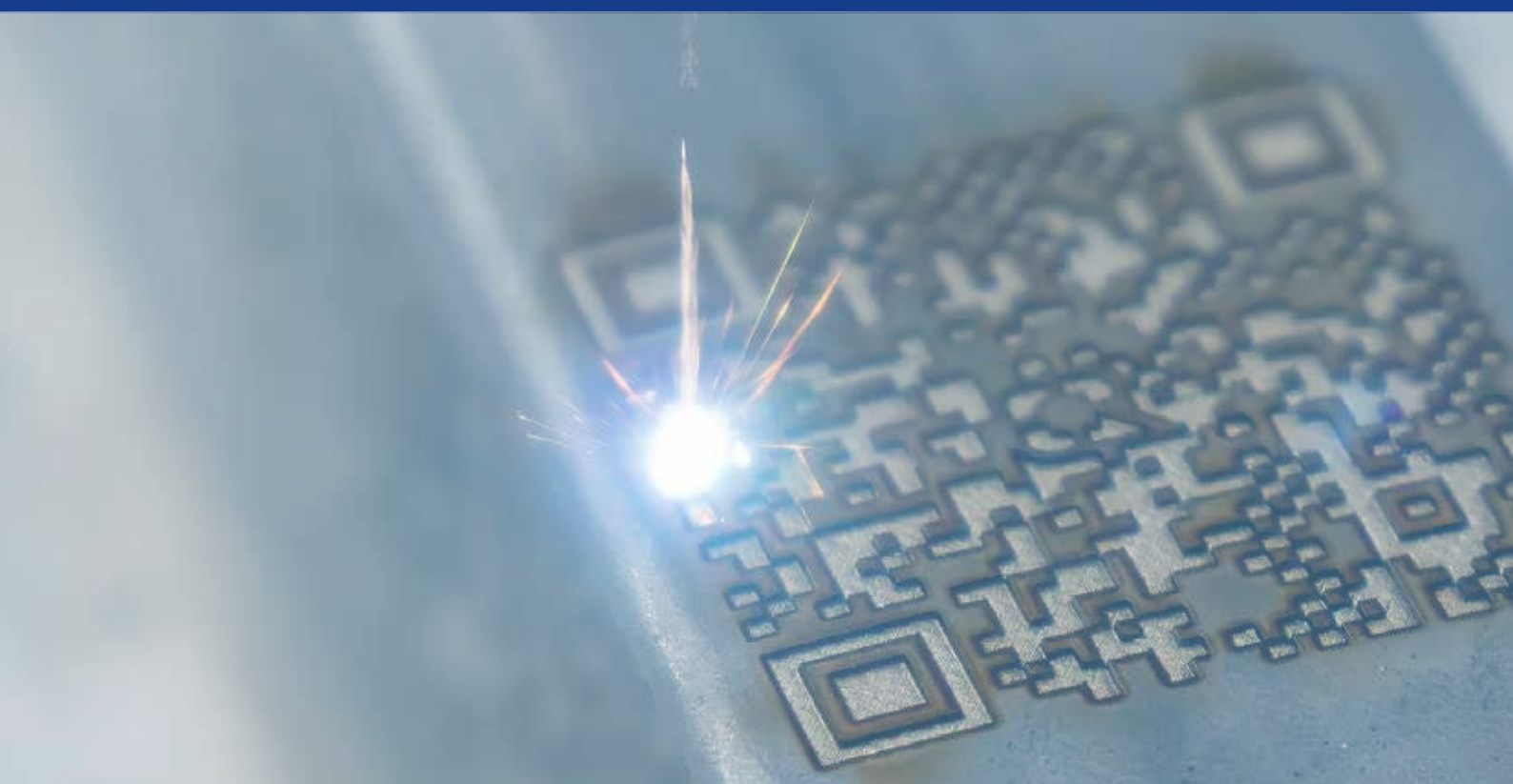

Datalogic Laser Marking is able to provide the best laser technology solution for your application, from fiber laser to solid state and CO<sub>2</sub>, powered by the latest software platform and hardware controller.

With the increasing popularity of Fiber lasers in recent years, Datalogic invested aggressively in this technology, and now we can offer a complete range of proprietary fiber laser sources. Moreover, when selecting a laser marker it is important to choose the best technology for the application and material that meets the requirements for speed, quality and budget.

Datalogic's product portfolio provides users the ability to select the perfect technology to provide the best results through a single software platform with flexible controller and integration I/O options.

No other manufacturer is so vertically integrated on Fiber technology (Pulsed and MOPA), Solid State technology (IR & UV) software and hardware controllers, scanning heads and marking system design!

## ONE-RACK MARKING CONTROLLER

System setup and commissioning are made easy with Datalogic's Embedded Marker Controller (EMC) powered by LIGHTER Software Suite.

The unified 19-inch controller with standardized controls and I/O connections allow integrators to easily switch between Datalogic's laser technologies (Solid State, Fiber, CO<sub>2</sub>) without any connection or wiring complications.

Everything required for your marking application is now included: a 100-240 VAC power supply, a Windows 10 IoT embedded PC, an iMark Embedded Laser controller with four independent axis controls (X, Y, Z, rotating axis), dedicated connectors for Marking On Fly (MOF), Datalogic's MATRIX code reader, and much more. All units come equipped with a built-in, pre-configured Teamviewer host to provide complete remote support from Datalogic.



## TECHNOLOGIES

### SOLID STATE

High Peak power,  
Multi wavelength,  
for demanding  
materials

### FIBER LASER

High reliability  
fiber laser  
technology

### CO<sub>2</sub>

Consolidated  
technology for  
painted, coated or  
organic material



#### SOLID STATE LASER MARKER: VLASE SERIES

The long history of market-leading Solid State technologies has enabled Datalogic to create the most comprehensive product portfolio in the marketplace by offering solutions with a wide variety of applications in multiple wavelengths.

DL product portfolio offers industrial grade solutions for Infrared and UV in a wide power range.

##### Solid State key features:

- Best-in-class laser peak power
- Two different wavelengths for best results even on highly reflective or high-stability materials
- Excellent beam quality and marking accuracy
- Low thermal footprint to ensure high contrast on thermoplastic materials and low impact on thermal sensitive components



#### FIBER LASER MARKER: UNIQ & AREX400 SERIES

Innovative design and performances combined with state-of-art technology, for the most demanding applications and industries. Datalogic's AREX 400 and UniQ product lines are robust reliable and cost effective. Fiber laser technology is the solution of choice for high-end applications where speed, quality and efficiency are critical.

Fixed pulse width models (100 ns) ensure great thermal effect on metal marking materials, for high efficiency metal annealing and engraving.

Adjustable pulse width model (4 - 250 ns) based on MOPA technology offers the highest level of flexibility on heat-sensitive materials, and ensure the highest contrast on thermoplastic materials.

##### Fiber Laser key features:

- Ultra-compact, rugged IP64 scanhead fully protected against dust, water and oil droplets
- Low noise level
- Fast turn-on time, zero warmup
- High stability, reliable process
- Excellent on metal and plastic surfaces



#### CO<sub>2</sub> LASER MARKER: EOX SERIES

CO<sub>2</sub> laser technology is still the best solution to provide permanent laser marking for industrial traceability and coding on paper, carton, organic materials, coated/painted materials and plastic.

Long wavelength (10.6 μm) ensure good results even on glass, rubber, food, wood and many other materials.

##### CO<sub>2</sub> Laser key features:

- Excellent on paper, cardboard, wood and plastics
- Marking on the fly compatible with variable speed
- Suitable for coding from medium to high throughput production lines

# How does a laser marker work?

Laser marking is a way to permanently mark a physical item for branding, tracking, coding, personalizing, either for security or quality control reasons.

During the process, an intense, collimated laser light beam is focused on the surface of a target. By scanning this concentrated spot with moving mirrors on the target's surface the laser beam can create image.

Depending on laser source characteristics, an instantaneous peak power density of several hundred kilowatts are delivered on the target causing instantaneous modification to the surface.

Laser Marking does not involve the use of inks, masks, solvents, acids, nor does it require tools which contact the engraving surface and wear over time. These properties distinguish laser engraving from alternative engraving or marking technologies where inks or bit heads have to be replaced regularly.

While most forms of engraving result in a loss of some of the marked material when it is etched away, laser marking results in essentially no loss of material. Instead, the laser is used to create a shift in the color of the material, creating a visible, virtually indestructible mark with minimal impact to the item.

## HOW DOES LASER MARKING WORK

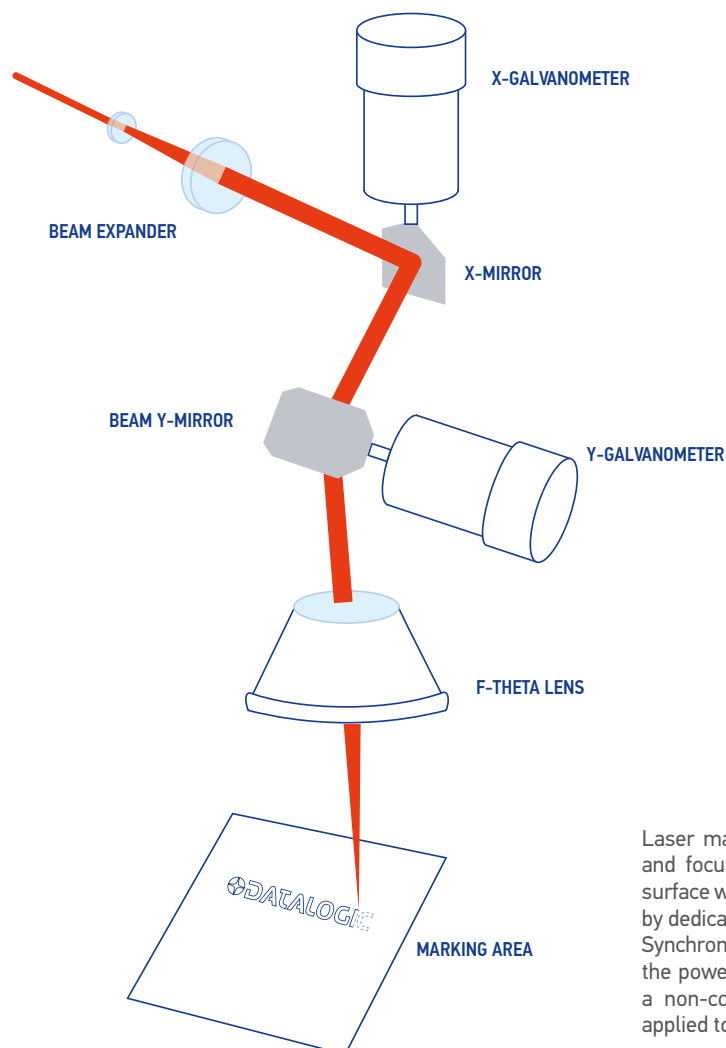

Laser marking is obtained by delivering and focusing a laser beam on a target surface with motorized mirrors controlled by dedicated hardware and software. Synchronizing the XY movement with the power modulation of the laser beam a non-contact and permanent mark is applied to the target surface.

# Advantages of laser marking

Laser marking technology is the preferred choice in manufacturing due to its intrinsic advantages:

## **PERMANENT & DURABLE**

Abrasion proof, water, solvent, oil, temperature, UV resistant marking counterfeit proof  
Strong interaction with substrate: Tamper proof, difficult to alter or remove

## **LONG TERM CONTRAST & READABILITY**

Human and machine readable over long periods of time

## **NON CONTACT, CLEAN & DRY**

Solvent and ink free with no mechanical interactions with materials, complex clamping or special handling systems, with no drying time

## **FAST - HIGH PRODUCTIVITY**

On-the-fly and static marking with up to 600 characters per second

## **HIGH RESOLUTION, HIGH QUALITY**

High resolution for graphics, logos or fonts, up to 600 DPI

## **FLEXIBLE**

Fixed, variable, or dynamic text, full vectorial and bitmap graphics, 1D & 2D bar codes

## **RELIABLE & ENVIRONMENTALLY FRIENDLY**

Laser marking requires no paint, ink, solvents, chemicals, or other consumables, resulting in an exceptionally low environmental impact. This allows environmentally-conscious companies to benefit from both cost savings and the eco-friendliness of laser marking solutions



# Laser Marking processes

## 1 - Annealing

### Materials:

Ferrous metals (iron, steel)  
Titanium

### Laser marking product:

AREX Series- Fiber Laser Marker  
VLASE Series – Solid State Laser Marker  
UNIQT™ - Fiber Laser Marker

Laser annealing is a marking technique that uses laser irradiation to thermally induce local oxidation without noticeable material ablation, this process creates an indelible, permanent black mark without any cracks, depressions or burrs suitable for already finished surfaces like high surface precision on surgical instruments and tools.

Typical annealing processes usually penetrate 20 to 30 µm deep in the metal surface, resulting in a stable marking that is corrosion-proof ensuring the mark cannot be removed by acid, solvents, or abrasive techniques.

This dark, permanent mark is perfect for medical device applications where marks withstand passivation, salt spray testing, and autoclaving and where material removal is prohibited to ensure part integrity and surface quality.

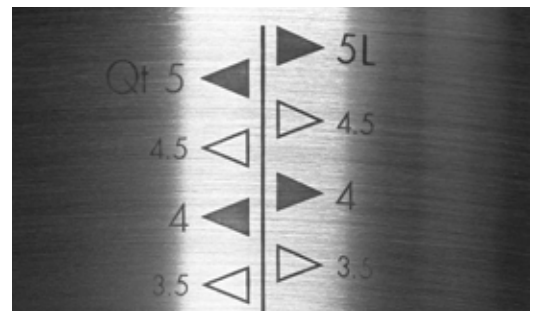
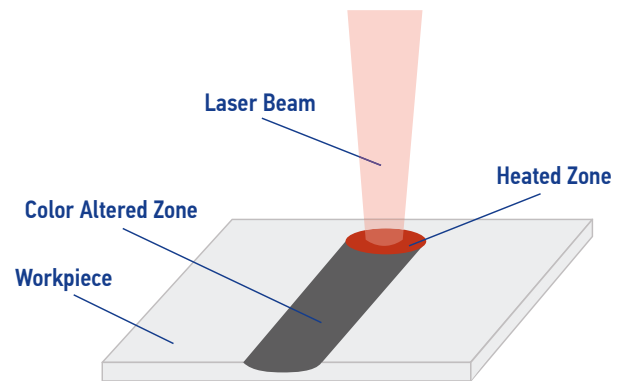

## 2 - Engraving

### Materials:

Metals  
Thermoplastic  
Wood, organics

### Laser marking products:

AREX Series- Fiber Laser Marker  
VLASE Series – Solid State Laser Marker  
EOX Series – CO<sub>2</sub> Laser Marker  
UNIQT™ - Fiber Laser Marker

In laser engraving, the laser beam locally overheats the workpiece material to the vaporization point. In some cases, thermal effects are very evident with large Heat Affected Zones (HAZ), colored oxides can be produced at the bottom or the engraving further accentuating the marking.

A depression is created in the workpiece through melting and/or vaporization of material. Typical engraving depths vary between 0,001mm to 0,1mm and almost any material can be engraved with a suitable laser source (Fiber, YAG, CO<sub>2</sub>).

Deep engraving is a method to create durable, direct and forgery-proof product marking which is resistance to wear and corrosion, even after painting or coating processes as used in automotive applications.

Deep engraving also includes 3D marking, which is the progressive removal of several layers of material at different depths to create a three-dimensional carving into the workpiece. 3D marking relies on external devices to reposition the focus field to affect different layers along the Z axis. Typical deep engraving depths vary between 0,1mm to 5mm.

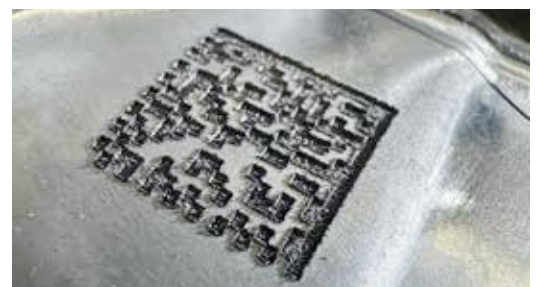
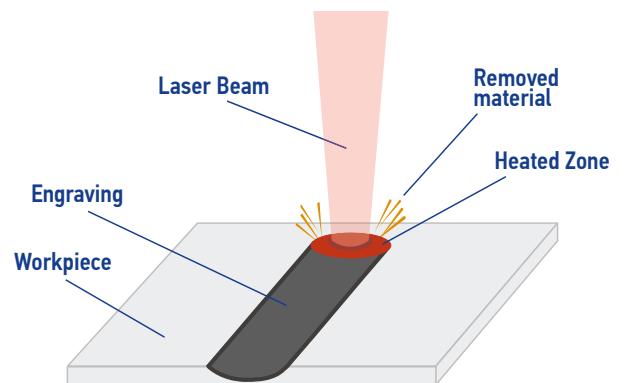

### 3 - Surface etching

**Material marked:**

Metals

**Laser marking product:**

AREX series - Fiber Laser Marker  
VLASE series – Solid State Laser Marker  
UNIQ™ - Fiber Laser Marker

The laser etching process consists of using laser irradiation to alter the superficial finish of a metal and create contrast by enhancing the way it reflects and diffuse ambient light.

Depth of penetration usually does not exceed 0.01mm. Laser etching is probably the most widely used high speed laser marking process.

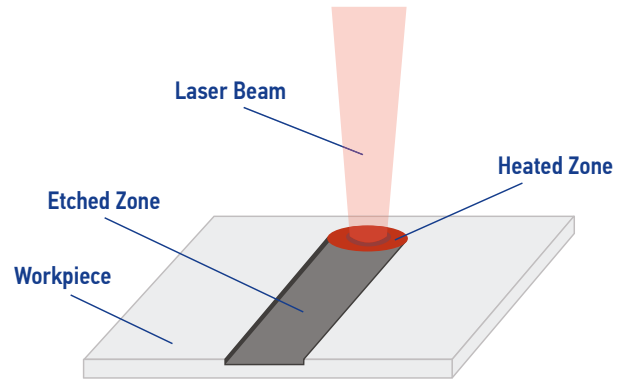

### 4 - Coating ablation /Paint stripping

**Materials:**

Multiple materials, depending on coating

**Laser marking product:**

AREX Series- Fiber Laser Marker  
VLASE Series – Solid State Laser Marker  
EOX Series – CO<sub>2</sub> Laser Marker  
UNIQ™ - Fiber Laser Marker

Ablation marking process consists of the partial/complete removal of one or more coating layers which exposes the contrasting color of the substrate material.

This process is popular for backlight marking and 'night & day' buttons and keys in the automotive, computer and mobile electronics industries, where a dark spray coating is applied on a transparent substrate, and then selectively ablated by laser irradiation. Short pulses with high peak reduces the thermal impact on the material resulting in high resolution marking. Laser ablation can also be used to prepare substrates for other steps in the production process. For example welding of oily, dirty or oxidized surface or when an electrical contact is needed on metal frames. In these applications, cleaning and chemical agents can be eliminated and replaced with laser ablation.

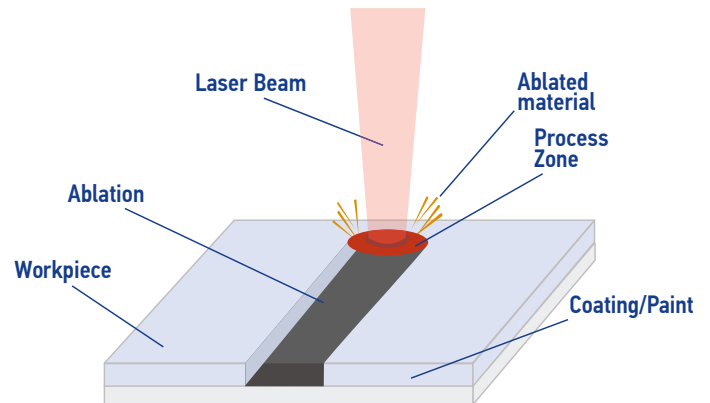

# Laser Marking processes

## 5 - Foaming

### Materials:

Thermoplastic Materials

### Laser marking product:

AREX Series- Fiber Laser Marker

VLASE Series – Solid State Laser Marker

UNIQT™ - Fiber Laser Marker

Due to laser absorption and low thermal conductivity the local workpiece temperature rises to its melting point. Small gas bubbles appear in the molten material, which increases its volume creating a type of plastic foam. The processed area appears much brighter than the surrounding material. This process is typically enhanced using laser marking additives that increase contrast and the reliability of the marking process. The foaming marking process is usually tactile and with poor scratch resistance.

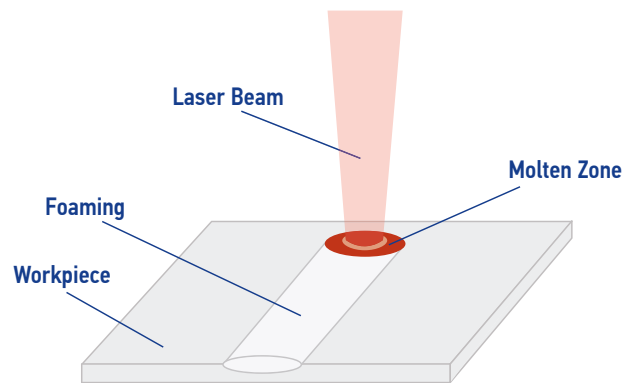

## 6 - Color change / Blackening / Bleaching

### Materials:

Thermoplastic Materials

### Laser marking product:

AREX Series- Fiber Laser Marker

VLASE Series – Solid State Laser Marker

UNIQT™ - Fiber Laser Marker

On some thermoplastic materials “UV lasers” (third harmonic lasers @ 355 nm) can be used for bleaching and photo reduction marking processes. This effect is also called “cold marking” for the reduced “thermal footprint” on the substrate.

The use of laser-sensitive additives in plastics can generate considerable advantages. Additives in plastics are able to increase outline sharpness and contrast and thus boost readability of the marking contents e.g. of machine-readable codes. Used with transparent and semi-transparent materials, additives lead to a uniform contrast. Additives in plastics increase the diversity of product colors and are of crucial importance for the markability of certain materials.

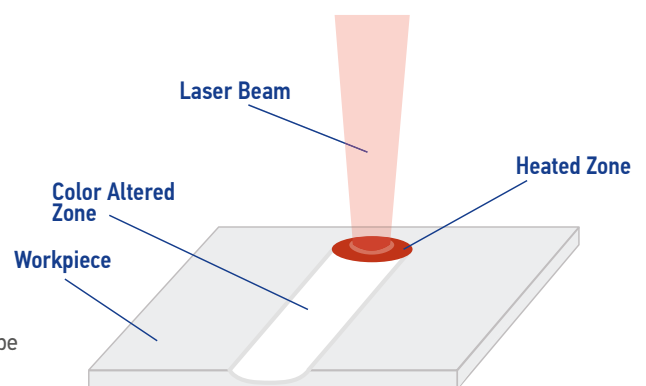

## 7 - Carbonization/Engraving With Carbonization

### Materials:

Thermoplastic Materials  
Paper, Wood, Organics

### Laser marking product:

AREX Series- Fiber Laser Marker  
VLASE Series – Solid State Laser Marker  
EOX – Series – CO2 Laser

Carbonization of one or more specific pigments, flame retardants or other additives will provide consistent marking with sharp contrast in most light colored thermoplastic materials. Engraving may be present depending on the vaporization of the material and its absorption level.

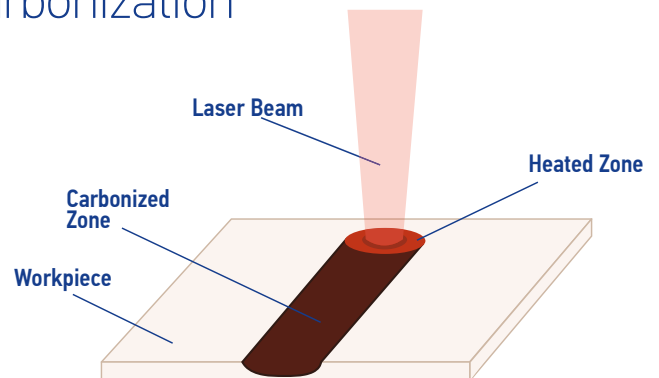

## 8 - SubSurface Laser Engraving (SSLE)

### Materials:

Glass, transparent plastics

### Laser marking product:

AREX Series- Fiber Laser Marker  
VLASE Series – Solid State Laser Marker

Focusing intense laser radiation below the surface of a transparent object creates a mark made of micro-cracks induced by localized absorption of the laser light. As a result, microscopic cracks cause multiple internal light reflections which makes the spot look white. Without affecting the polished surfaces, two and three dimensional images can be created inside of the glass. This technique is popular for decoration as well as tamper-proof traceability.

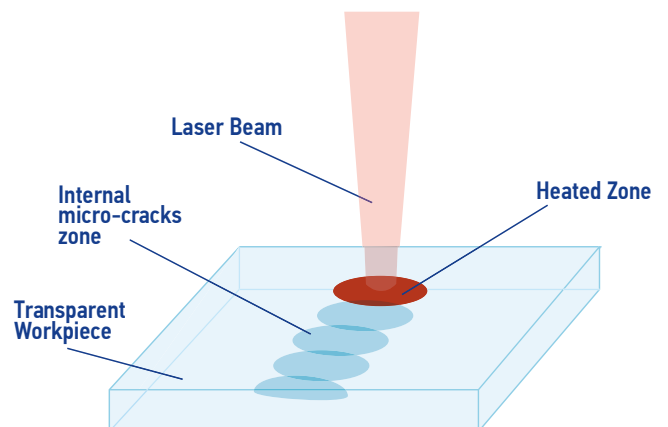

# Laser Marking processes

## 9 - Color Marking On Ferrous Metals And Titanium

### Materials:

Ferrous metals (iron, steel)  
Titanium

### Laser marking product:

AREX 20 MW – MOPA Fiber Laser Marker

Laser Color Marking of stainless steel and titanium is a well-known marking technique but still with a limited diffusion in the industry.

Like laser annealing, laser color marking is based on surface oxidation, varying different laser parameters will result in different oxide coatings that can be seen as different colors by the viewer.

Most important parameters in laser marking are the focal spot diameter, power on sample, marking speed, line spacing, marking direction, repetition rate and pulse length.

Thanks to the capability to control laser pulse-width, and to its high stability, MOPA fiber lasers enable homogeneous and reliable color marking on ferrous metals and titanium.

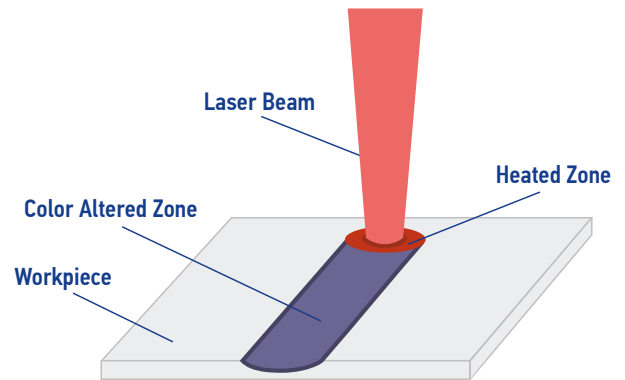

## 10 - Black Marking On Anodized Aluminum

### Materials:

Anodized aluminum

### Laser marking product:

AREX 20 MW – MOPA Fiber Laser Marker

The so called “black marking” is a technique widely used by mobile device manufacturers to mark logos and serial numbers on the anodized aluminum case with high contrast, pleasing appearance and feel and no damage on the protective oxide layer.

Thanks to the capability to run at short pulses, to the high level of control of energy and peak power, Mopa fiber lasers are the best choice to combine real black appearance with the benefits of laser marking without corrupting the corrosion properties of the coated material.

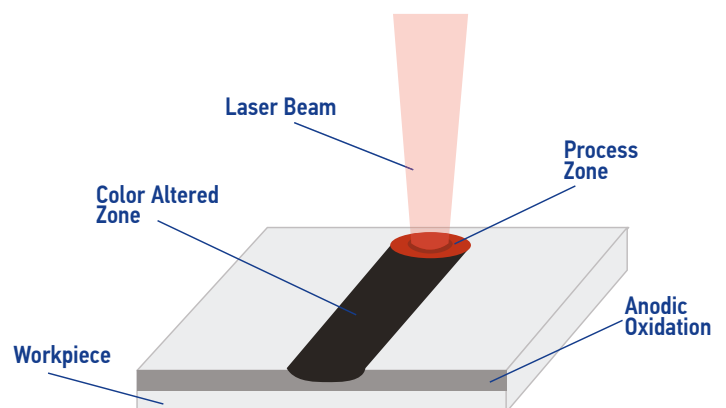

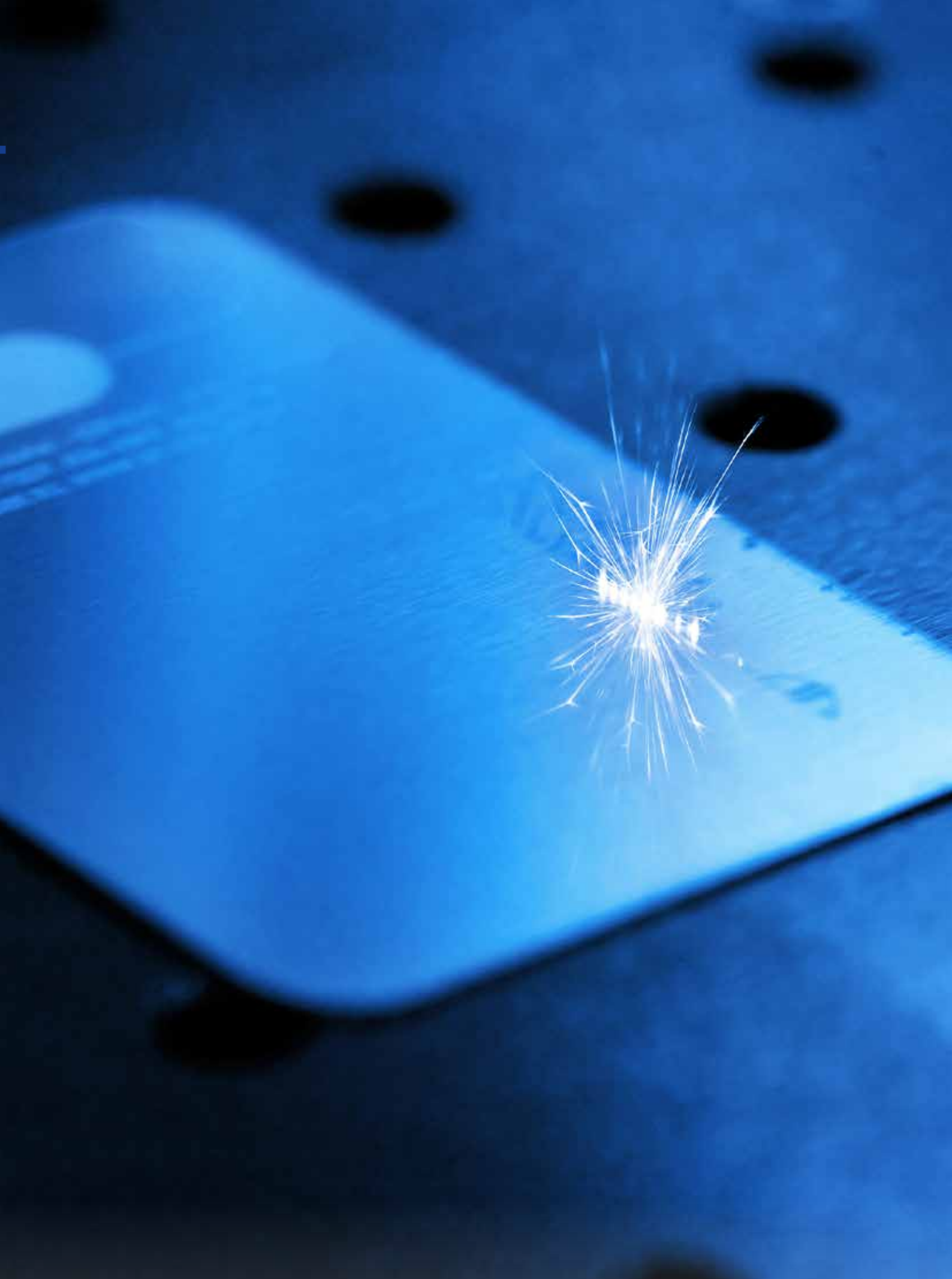

# Lighter Software

Thanks to its full graphical interface, **LIGHTER** combines advanced editing features with laser setup, controls and diagnostic for complete, flexible and ease of use laser marking system control.

**LIGHTER SUITE** is based on a quick-to-learn powerful WYSIWYG (What You See Is What You Get) graphical LASER EDITOR and an easy-to-use, LASER ENGINE. This two-GUIs approach guarantee effective results in term of flexibility and operating speed.



## LASER EDITOR: Advanced Editing Function

- Full Graphical interface, to easily design and edit any kind of marking layout.
- Built-in Property Browser for fast setting of all parameters
- Creates and edits texts, codes, imported vectorial graphics, logo, etc.
- Comprehensive and powerful coding library for 1D and 2D code (100+ code styles available)
- Direct import and edit of bitmap and vectors logo and graphics (BMP, PNG, GIF, JPG, SVG, TIF, PLT, DXF, DWG, AI, ...)
- Advanced filling and hatching features for objects and pattern structures with various styles.
- True Type Font (TTF) import tool, with advanced editing features (rounded text, slanted, compression etc.)
- Unicode language support
- Mark Preview – exact view of marking vectors.
- Clone function , array capabilities for IC marking,
- Gray tones marking

## ADVANCED HATCHING FEATURES AND CAPABILITIES

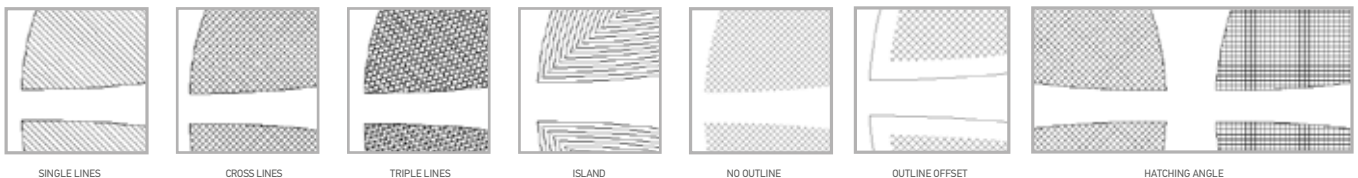

ABCDEFGHIJKLMNOPQRSTUVWXYZ - 1234567890  
 ABCDEFGJKLMNPOQRSTUVWXYZ - 1234567890  
 ABCDEFGJKLMNPOQRSTUVWXYZ - 1234567890  
*Script - A B c d e f g h i j k l m n o p q r s t u v w x y z - 1 2 3 4 5 6 7 8 9 0*



احصائيات الموقع    搜索开放源代码  
 한국어/조그말    अन्वेषी से हिन्दी



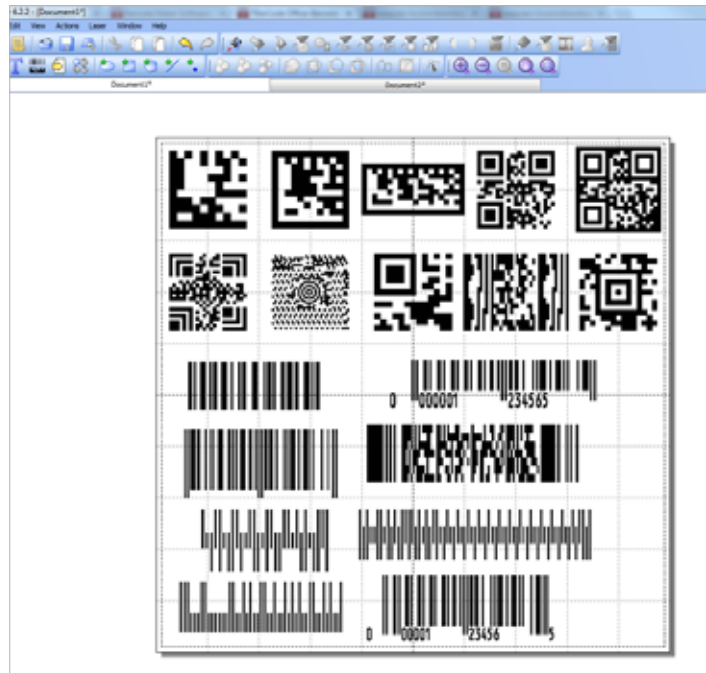

Embedded coding library supports linear, 2D, GS1 and composite symbologies. QR-Code, Datamatrix, are supported as well as other 100+ code styles.

## AUTOMATION CAPABILITY

**LIGHTER SUITE** incorporates additional features to simplify automation and integration with automatic lines.

- Embedded Stepper Motor controller: up to 4 axes independent Mechanical Axis(: X, Y, Z and Rotary/indexer) at layout level
- User configurable general purpose I/Os with built-in I/Os monitor
- Marking-on-Fly (MOF) capabilities with Setup Wizard for easy set-up
- Sequence Editor to easily create sequential automated in a few clicks
- Powerful built-in counters and Global Variables Manager for serializing applications
- Built-in Material database
- Built in Script Engine for interaction with local or centralized database

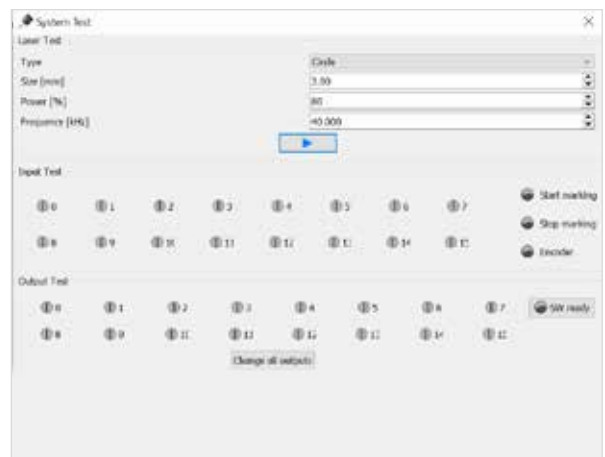
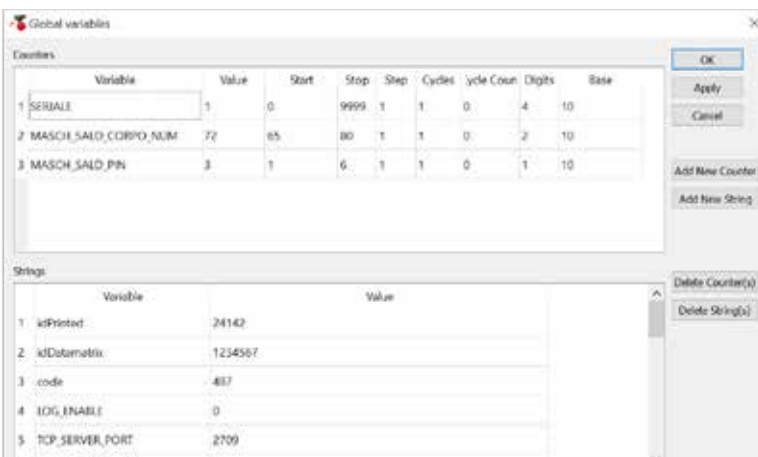

GLOBAL VARIABLES MANAGER

LASER TEST & I/O MONITOR

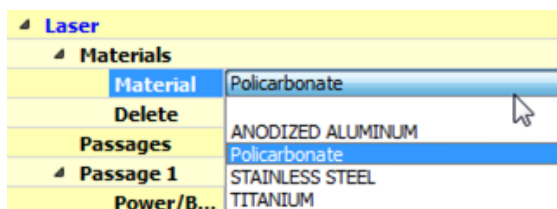

MATERIAL DATABASE

# MA.R.V.I.S. : MARK READ VERIFY INTEGRATED SOLUTION

Available with the LIGHTER software suite the new MARVIS (Mark Read Verify Integrated Solution) is the new Datalogic's solution for laser marking parts traceability.

LIGHTER MARVIS™ represents an important step-a-head in the MARK & VALIDATE application setting a new standard in term of ease integration and ease of use.

Thanks to innovative approach LIGHTER MARVIS™ merges the capability to control both the full family of DATALOGIC Laser Markers and the entire family of MATRIX code readers, in a user friendly, simplified fully graphical interface.



## MARVIS: MARK & VALIDATE IN ONE CLICK



### Object-Oriented Configuration

In the Lighter Suite, each object is associated with specific LASER parameters and READER configuration; loading a graphical layout will automatically retrieve and update laser and reader configurations. Product reconfiguration or format changes are as simple as loading a graphical layout.



### Connectivity

The LIGHTER Suite allows OEMs and Machine builders to develop a complete and cost effective Laser Marking Station, based on embedded hardware and software resources (such as STAND ALONE mode) or to design an advanced Laser Marking Solution able to control machinery over a simple Ethernet connection with a supervisor computer (MASTER-SLAVE mode). Lighter Suite natively embeds Ethernet TCP/IP and EtherNet/IP protocols.

### Advanced Editing Function



- Easily create, import and edit texts, shapes and logos
- One-click code generator for 1D and 2D symbologies
- Object-related Property Browser for fast adjustment of Marker and Reader parameters
- Imports Bitmap and Vector files (DXF, DWG, PLT, PDF, AI, SVG, BMP, JPG, PNG and TIFF...)
- Advanced filling featured with various laser-optimized patterns



### Scripting programmability

The LIGHTER Suite integrates the IDE (Integrated Development Environment) providing the users with a full set of tools to be used for extremely flexible customization. The programming language is ECMAScript (also called JavaScript). With Project Editor it is possible to:

- Control the entire marking process
- Create and fully customize marking layout and its content at runtime
- Interact with local or centralized databases
- Create alternative customized interfaces
- Interact with Third Party devices

### Integrated Configuration and Setup



- IP address discovery and connection management
- Dedicated Digital output for in-line parts selection
- Dedicated Digital input for deferred reader trigger
- Configurable images storage pool
- New Code Quality Training feature to automatically define code quality threshold from "Golden Sample"
- Patent Pending "Quality Grade Metric Profile" (QGP)

### Runtime Production Statistics and Reports



Built-in validation statistics dashboard. Configurable log file with Quality Reporting and code images.

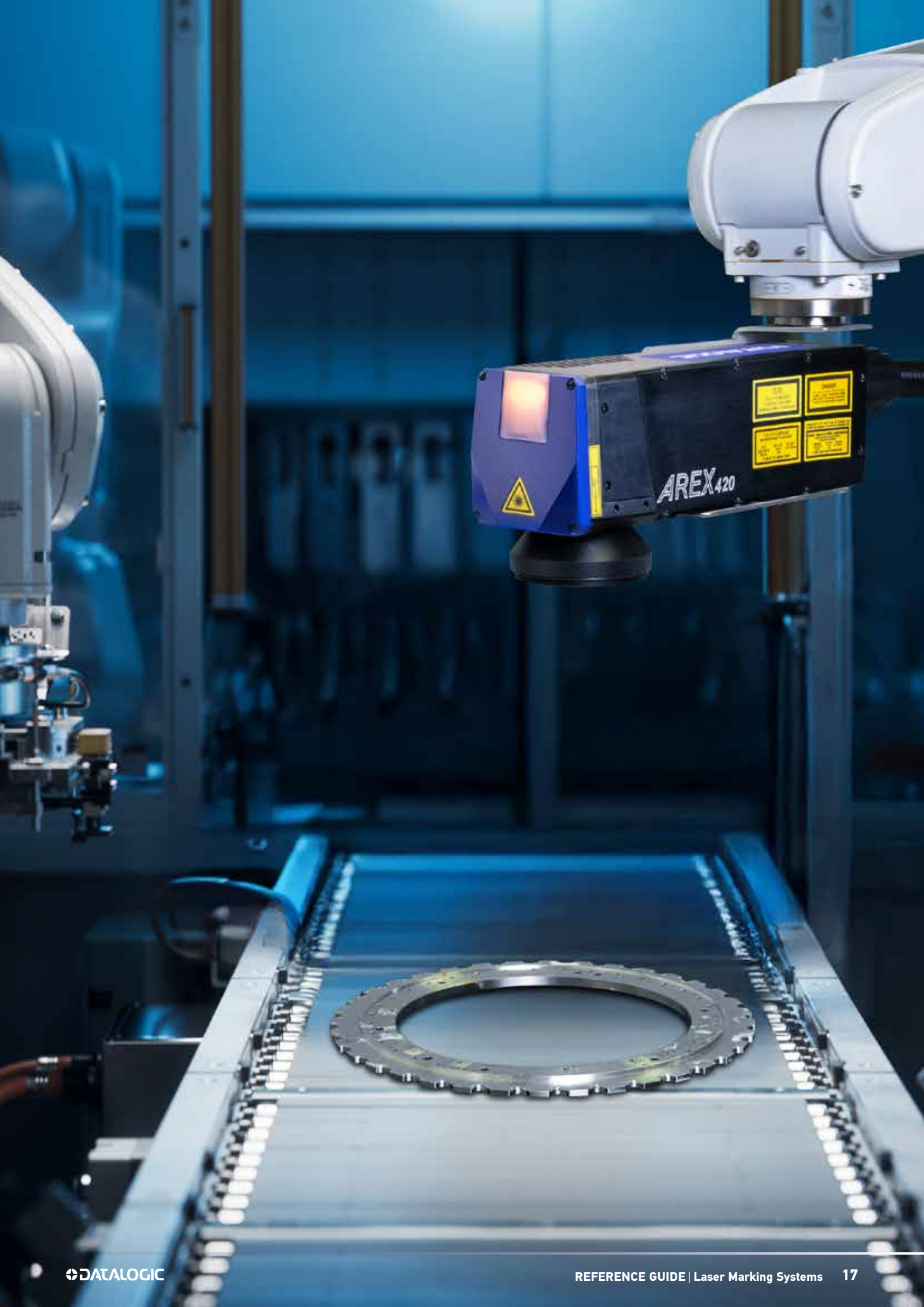

# Fiber Laser Marking

## FIBER LASER

Fiber lasers are not new in Industrial Laser Marking, CW fiber sources have been used for high speed marking of integrated circuits (IC) since 1998. In recent years, fiber lasers have tremendously progressed in terms of flexibility and overall performance enabling the 'Fiber Revolution' in the laser market.

With a monolithic, solid state, fiber-to-fiber design which eliminates mirrors and optics to align or adjust, fiber lasers have technological advantages that dramatically improve reliability and repeatability of laser processes.

Fiber lasers also offer integration and operational advantages:

- Fiber lasers are compact and deliver their energy through a flexible optical fiber
- Fiber lasers are scalable and more efficient than any other laser technology, with wall-plug efficiencies greater than 30%
- Fiber lasers offer higher and stable beam quality and excellent pulse-to-pulse stability ensuring the best repeatability over time, especially for critical marking processes
- Q-Switched Fiber lasers offer a long pulse-width (typ 100 nsec) that make these sources the first choice for marking metal in the automotive industry
- MULTIWAVE M.O.P.A. fiber laser technology offers the capability to select the emission pulsewidth from 4 ns to 250 ns ensuring superb marking performances in term of process optimization and repeatability.

## APPLICATIONS & MATERIALS



High contrast marking on metal



High contrast marking on metal



Engraving & deep engraving on metal



Color change on plastics



Color change on thermoplastic polymer with additive

# UNIQT<sup>TM</sup>

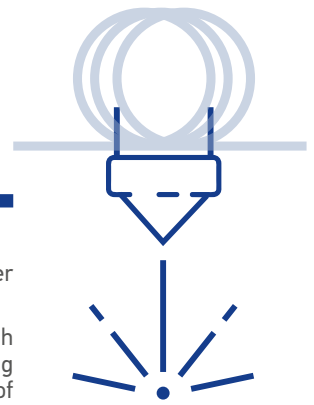

UniQ<sup>TM</sup> marker is a revolutionary and innovative approach to Fiber Laser Marking.

UniQ<sup>TM</sup> fiber laser marker represent the perfect combination of a high performance fiber laser into a innovative, ultra-compact housing designed to provide an effective solution to the recent request of shorter, smaller production lines, in order to reduce footprint and floor area consumption.

Thanks to its advanced internal design, UniQ<sup>TM</sup> laser marker does not need any high-IP grade external cabinet, controller or power supply, and is totally free from delivery fiber constraints such as fiber length and fiber bending limitations.

The IP54 rated innovative housing guarantees maximum protection even in harsh factory environments and industrial applications.

UniQ<sup>TM</sup> laser marker works seamless with Datalogic's Lighter Suite, a powerful, quick and intuitive marking software, and is fully compatible with the latest Datalogic I/O interfaces.

### Features & benefits

- Powerful 15W fiber laser source
- All-in-one, Fully integrated ultra-compact device
- Rugged IP54 rated housing
- All included: No external controller, no external power supply needed
- No fiber delivery constraints
- Built-in second generation EMC (Embedded Marking Controller)
- Great Money Vs Watt ratio
- Powered by Lighter software Suite

### Main applications

#### Factory Automation

- **Automotive**
  - High Contrast DPM for traceability, quality control, testing & sorting
  - High stability marking for end-of-life traceability
- **Industrial Electronics**
  - High contrast marking on additivated plastic materials
  - High speed coding and branding on industrial electronic devices

#### Other

- **Medical & surgical tools**
  - Contactless and Clean Direct Marking Process for Branding & Personalization
  - Instant permanent marking: no drying time, no post processing, no solvent or additive
- **Precision Mechanics**
  - High precision marking with no mechanical stresses
  - Clear and precise annealing even on very small surface

PARAMETER		UNIQT
<b>Wavelength</b>	nm	1060 – 1080
<b>Nominal power</b>	w	15
<b>Repetition rate range</b>	kHz	15 - 100
<b>Pulsewidth</b>	ns	120
<b>Pulse energy</b>	mJ	0.75
<b>Peak power</b>	kW	10
<b>Marking capabilities</b>		Standing, Rotary axis, On the fly (marking in motion)
<b>Integration</b>		Up to 4 mechanical axis driving capabilities (stepper motor) Up to 10 digital inputs and 10 digital output fully programmable dedicated connectors for Datalogic's Encoder and Photocell
<b>Interface</b>		Ethernet, RS 232, 4x USB
<b>Power</b>		100/240 VAC – 50/60 Hz
<b>Cooling system</b>		integrated air-cooled
<b>Dimensions &amp; weight - LxWxH</b>		497x150 x183 mm - kg 10

## MODEL SELECTION AND ORDER INFORMATION

ORDER NUMBER	DESCRIPTION	FULL DESCRIPTION
901390001	UNIQT 1150-1341 Fiber Marker	UniQ 15W@1064 with F160S-M39 Lens W10
901390002	UNIQT 1150-1641 Fiber Marker	UniQ 15W@1064 with F254S-M39 Lens W10
901390003	UNIQT 1150-1741 Fiber Marker	UniQ 15W@1064 with F254L-M85 Lens W10
901390004	UNIQT 1150-1941 Fiber Marker	UniQ 15W@1064 with F100L-M85 Lens W10

# Fiber Laser Marking

## AREX400



AREX400 Series is the new generation of industrial grade laser markers based on fiber technology dedicated to direct part marking in manufacturing industries such as the Automotive, industrial Electronics, Tooling and precision mechanics. Thanks to its exceptionally small and robust scanhead machined from solid aluminum Arex400 is unbeatable in tight space installation where small footprint is mandatory and reliability is a must.

Arex400 incorporates the new LASER GREENSPOT, the programmable visual indicator for immediate and effective visible process feedback directly on marking area, native support to micrometric displacement sensor, embedded communication protocols (TCP/IP, Ethernet IP, Profinet), built-in SLO (Safety Laser Off) and reduced noise level down to 65 dB.

The AREX400 Series includes Pulsed Laser sources from 10W to 100W, along with a 20W MOPA source. MOPA technology offers superior control of laser emission, allowing for marking on a broader range of materials with increased speed, enhanced resolution, and precision, even on thermally sensitive materials.

### Features & benefits

#### Quick installation and setup

AREX400 design dramatically simplifies and speeds up machine design and system integration thanks to Embedded Marking Controller (EMC) with LIGHTER Software Suite that ensures quick and easy installation, setup, control and system diagnostics even from remote via Ethernet TCP/IP. The Built-in step motors controller, totally integrated in software editor, greatly simplifies integration of rotary indexers, x-y tables and z axis

#### Applications

- Traceability: High contrast DPM (Direct Part Marking) coding
- Branding and Texturing: High resolution logos and graphics

### Materials

- **Metals:** Stainless Steel, High-speed Steel, Carbide, Steel, Carbon steel, Copper, Iron, Ferrous Metals, Alloys, Magnesium, Aluminum, Brass, Gold, Silver, Platinum, Titanium ...
- **Coated / Painted Metals:** Anodized Aluminum, Painted metals, electrodeposited metal alloy coatings, etc.
- **Plastic:** Polycarbonate (PC) Polysulfone (PSU), Polyphenylene sulfide (PPS), Polystyrene (PC), Acrylonitrile Butadiene Styrene (ABS), Polyethylene terephthalate (PET) ...
- **Ceramics:** Aluminum Oxide (Al<sub>2</sub>O<sub>3</sub>), Zirconium Oxide (ZrO<sub>2</sub>), Aluminum Titanate (Al<sub>2</sub>TiO<sub>5</sub>), Silicon Carbide (SiC/SiC), Zirconium Oxide (ZrO<sub>2</sub>)

### industries

- Automotive
- Industrial electronics,
- Tooling and precision mechanics
- Visual communication,
- Medical/surgical tools and implants

PARAMETER		AREX 410	AREX 420	AREX 420 MW	AREX 430	AREX 450	AREX 401
<b>Nominal power</b>	[W]	10	20	20	30	50	100
<b>Peak power (max)</b>	[kW]	10	10	≥ 10	10	10	10
<b>Pulse energy</b>	[mJ]	1,0	1,0	≥ 0.75	1,0	1,0	1,0
<b>Modulation</b>	KHz	2-200	2-200	20-500	2-200	2-200	2-200
<b>Pulsewidth</b>	ns	100	100	ADJ 4-250	100	100	100
<b>Marking capabilities</b>		Static, on the rotary indexer, on the fly (marking in motion); Extended-Layer (combination with X,Y Axis)					
<b>Fiber length</b>	[m]	3					
<b>Integration</b>		Built-in 4 axis step motors controller INPUTS: 10 programmable digital inputs OUTPUTS: 10 programmable digital outputs (NPN) Dedicated ports for Encoder, Photocell, MATRIX family Barcode Reader.					
<b>Interfaces</b>		6 x USB, 3 x Ethernet, 1 x RS-232, Digital I/O					
<b>Protection rating</b>		Head: IP64; Controller: IP31					
<b>Power supply</b>		100/240 VAC – 50/60 Hz – 400 W (MAX)					100/240 VAC – 50/60 Hz – 500 W
<b>Cooling</b>		Low noise, Forced air Low noise, Forced air					
<b>Head dimensions/weight</b>		96 mm x 90 mm x 326 mm – 3,5 kg					96 mm x 90 mm x 326 mm – 3,5 kg
<b>Controller dimensions</b>		113 mm x 432 mm x 434 mm – 17,5 kg					158 mm x 432 mm x 434 mm – 23,5 kg

F-THETA MODEL	MARKING AREA [MA] mm <sup>2</sup>	MARKING AREA [MA] mm <sup>2</sup>	FIXING DISTANCE [FD] mm	WORKING DISTANCE [WD] mm
	AREX 410 AREX 420 AREX 420 MW	AREX 430 AREX 450		
F = 100L	50 X 50	-	141	99
F = 160S	100X100	X	199	185
F = 160L	X	100X100	212	176
F = 254S	140X 140	X	305	285
F = 254L	180X180	170X170	372	301
F = 330L	220X 200	210X210	480	397
F = 420L	285X285	-	576	507

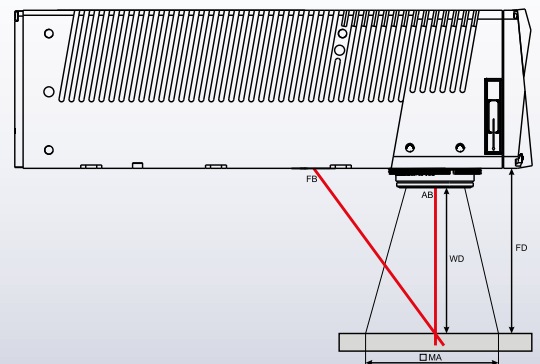

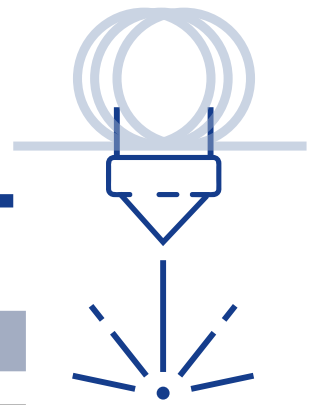

ORDER NUMBER	MODEL	DESCRIPTION
985180073	AREX 110-965 FIBER MARKER	AREX 110-965, 10W FIBER MARKER, IR@1070NM, F100L-M85, WIN10
985180074	AREX 110-365 FIBER MARKER	AREX 110-365, 10W FIBER MARKER, IR@1070NM, F160S-M39, WIN10
985180075	AREX 110-665 FIBER MARKER	AREX 110-665, 10W FIBER MARKER, IR@1070NM, F254S-M39, WIN10
985180078	AREX 120-965 FIBER MARKER	AREX 120-965, 20W FIBER MARKER, IR@1070NM, F100L-M85, WIN10
985180079	AREX 120-365 FIBER MARKER	AREX 120-365, 20W FIBER MARKER, IR@1070NM, F160S-M39, WIN10
985180080	AREX 120-665 FIBER MARKER	AREX 120-665, 20W FIBER MARKER, IR@1070NM, F254S-M39, WIN10
985180081	AREX 120-A65 FIBER MARKER	AREX 120-A65, 20W FIBER MARKER, IR@1070NM, F330L-M85, WIN10
985180082	AREX 120-B65 FIBER MARKER	AREX 120-B65, 20W FIBER MARKER, IR@1070NM, F420L-M85, WIN10
985180083	AREX 120-765 FIBER MARKER	AREX 120-765, 20W FIBER MARKER, IR@1070NM, F254L-M85, WIN10
985190005	AREX A20-965 FIBER MARKER	AREX A20-965, 20W MOPA FIBER MARKER, IR@1070NM, F100L-M85, WIN10
985190006	AREX A20-365 FIBER MARKER	AREX A20-365, 20W MOPA FIBER MARKER, IR@1070NM, F160S-M39, WIN10
985190007	AREX A20-665 FIBER MARKER	AREX A20-665, 20W MOPA FIBER MARKER, IR@1070NM, F254S-M38, WIN10
985190008	AREX A20-A65 FIBER MARKER	AREX A20-A65, 20W MOPA FIBER MARKER, IR@1070NM, F330L-M85, WIN10
985190009	AREX A20-B65 FIBER MARKER	AREX A20-B65, 20W MOPA FIBER MARKER, IR@1070NM, F420L-M85, WIN10
985190010	AREX A20-765 FIBER MARKER	AREX A20-765, 20W MOPA FIBER MARKER, IR@1070NM, F254L-M85, WIN10
985180086	AREX 130-465 FIBER MARKER	AREX 130-465, 30W FIBER MARKER, IR@1070NM, F160L-M85, WIN10
985180087	AREX 130-765 FIBER MARKER	AREX 130-765, 30W FIBER MARKER, IR@1070NM, F254L-M85, WIN10
985180088	AREX 130-A65 FIBER MARKER	AREX 130-A65, 30W FIBER MARKER, IR@1070NM, F330L-M85, WIN10
985180089	AREX 150-465 FIBER MARKER	AREX 150-465, 50W FIBER MARKER, IR@1070NM, F160L-M85, WIN10
985180090	AREX 150-765 FIBER MARKER	AREX 150-765, 50W FIBER MARKER, IR@1070NM, F254L-M85, WIN10
985180091	AREX 150-A65 FIBER MARKER	AREX 150-A65, 50W FIBER MARKER, IR@1070NM, F330L-M85, WIN10
985180092	AREX 150-B65 FIBER MARKER	AREX 150-B65, 50W FIBER MARKER, IR@1070NM, F420L-M85, WIN10
985180133	AREX 10C-765 FIBER MARKER	AREX 10C-765, 100W FIBER MARKER, IR@1070NM, F254L-M85, WIN10
985180134	AREX 10C-A65 FIBER MARKER	AREX 10C-A65, 100W FIBER MARKER, IR@1070NM, F330L-M85, WIN10
985180135	AREX 10C-B65 FIBER MARKER	AREX 10C-B65, 100W FIBER MARKER, IR@1070NM, F420L-M85, WIN10
985180136	AREX 10C-M65 FIBER MARKER	AREX 10C-M65, 100W FIBER MARKER, IR@1070NM, F160M-M60, WIN10
985180137	AREX 10C-N65 FIBER MARKER	AREX 10C-N65, 100W FIBER MARKER, IR@1070NM, F254M-M60, WIN10

## AREX400 configuration table



# Solid State Laser Marking

## SOLID STATE LASER

Diode Pumped Solid State Lasers (DPSSL) represent the most consolidated technology for laser marking applications and are still the most flexible solution to generate UV laser radiation.

The capability to provide extremely high peak power (up to 10 times higher than standard Fiber Lasers) and short pulse duration, make these laser sources very effective for difficult-to-mark materials such as highly reflective metals (copper, brass, silver, gold,...) or very stable polymer plastic.

Solid state lasers emission @ 1064 nm can be efficiently converted into UV emission @355nm (THG Third Harmonic Generation) enabling the capability to engrave virtually any kind of material with extremely high resolution and reduced Heat Affected Zones (HAZ). DPSSL are ideal for even thermally sensitive materials like silicon wafers, WLCSP, thin memory cards, ICs or highly reflective materials (copper, gold, silver).

DPSS lasers are suitable to process, damage free marking process high tech, multilayers, sensitive materials and components in Aerospace, and high technology Industry.

- DPSS lasers offer highest Peak Power and Short pulse width, providing cold process, extremely aggressive marking spot, even on stable and hard to engrave materials.
- DPSS lasers are available with IR and UV emission, for low thermal footprint marking process.
- DPSS lasers are the first choice for Thermoplastic Polymer Marking in electronics / electromechanical Industry.

## APPLICATIONS & MATERIALS - INFRARED



Color change on high stability plastic polymer



Paint stripping, coating removal



Night & day



Paint stripping



Surface modification



High contrast marking on highly reflective metal



Marking on copper



UV glass marking

# VLASE SERIES: IR & UV



VLASE SERIES now combines state-of-the-art YVO4 Solid State laser sources with the high flexibility and easy setup of the “ONE.RACK” embedded controller, providing machine builders, system integrators and end users a unified I/O interface for all three main laser marking technologies as well as only one control unit footprint and design. The high performance embedded controller provides easy operation in stand-alone configuration as well as sophisticated integration in master-slave configuration.

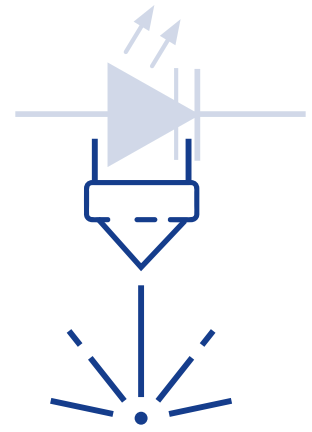

### Features & benefits

- Compact, high performance laser resonator
- Detachable resonator & optical fiber
- High Peak power up to 60 kW
- Infrared, Green and UV on same platform
- Build-in embedded controller
- Ethernet, RS232, 4x USB ports
- Dedicated I/O for photocells and encoders
- 4 axis embedded controller

### Main applications

#### Factory Automation

- **Automotive**
  - Coating removal and paint stripping for NIGHT & DAY application
  - High Contrast DPM for traceability, quality control, testing & sorting on high reflectivity materials
- **Electronics**
  - DPM traceability of thermal sensitive materials
  - Branding and high resolution product identification

#### Other

- **Healthcare**
  - Branding and high resolution product identification
  - DPM for traceability, quality control, testing & sorting, quality selection.
  - High quality marking on highly stable material for medical implants
- **High Precision Machining**
  - Branding and high resolution product identification
  - DPM for traceability, quality control, testing & sorting, wip track and control, quality selection

PARAMETER		VLASE IR 10	VLASE IR 20	VLASE UV 3
Wavelength	nm	1064	1064	355
Nominal power	w	10	20	3
Repetition rate range	kHz	10 ÷ 100	20 ÷ 200	20 ÷ 80
Pulse width	ns	15@10KHz	8@20KHz	8@25KHz
Max pulse energy	mJ	0.48@10kHz	0.55@20KHz	0.12@30KHz
Peak power	kW	32@10KHz	65@20KHz	14@25KHz
Marking capabilities		Standing, Rotary axis, On the fly (marking in motion)		
Integration		Up to 4 mechanical axis driving capabilities (stepper motor)		
Interface		Up to 10 digital inputs and 10 digital output fully programmable dedicated connectors Encoder and Photocell		
Optical fiber		Ethernet, RS 232, USB		
Power supply		Detachable – 3 meters standard - 5 meters optional (IR models only)		
Cooling system		100- 240 VAC 50/60Hz – 600 W max		
Resonator dimensions & weight		Air cooled		
Controller dimension & weight		686x128 x166 mm - kg 7		686x181x168 mm - kg 11
		480x430x122 mm - kg 15		

### MODEL SELECTION AND ORDER INFORMATION

ORDER NUMBER	MODEL	DESCRIPTION
985110073	VLASE 1109-1343 IR Marker	VLASE 10W@1064nm with F160S-M39 Lens W10
985110074	VLASE 1109-1443 IR Marker	VLASE 10W@1064nm with F160L-M85 Lens W10
985110075	VLASE 1109-1643 IR Marker	VLASE 10W@1064nm with F254S-M39 Lens W10
985110076	VLASE 1109-1743 IR Marker	VLASE 10W@1064nm with F254L-M85 Lens W10
985110080	VLASE 1209-1343 IR Marker	VLASE 20W@1064nm with F160S-M39 Lens W10
985110081	VLASE 1209-1443 IR Marker	VLASE 20W@1064nm with F 160L-M85 Lens W10
985110082	VLASE 1209-1643 IR Marker	VLASE 20W@1064nm with F254S-M39 Lens W10
985110083	VLASE 1209-1743 IR Marker	VLASE 20W@1064nm with F254L-M85 Lens W10
985110084	VLASE 1209-1A43 IR Marker	VLASE 20W@1064nm with F 330L-M85 Lens W10
985110085	VLASE 1209-1B43 IR Marker	VLASE 20W@1064nm with F 420L-M85 Lens W10
985110088	VLASE 3034-1843 UV Marker	VLASE 3W@355nm with F= 103-M39 Telecentric Lens W10
985110089	VLASE 3034-1443 UV Marker	VLASE 3W@355nm with F160L-M85 Lens W10

# CO<sub>2</sub> Laser Marking

## CO<sub>2</sub> LASER

Developed over 50 years ago, the CO<sub>2</sub> laser has captured the largest portion of the laser materials processing market. Current day CO<sub>2</sub> lasers are the best solutions for high thermal impact marking with wavelengths 10x longer than DPSS and Fiber lasers. The long wavelength (10600 nm) is extremely efficient on typical packaging materials, such as:

- Paper, Corrugated Cardboard
- Glass, Ceramic
- Plastic polymer, Rubber
- Painted, coated material (metals, plastic PCB)

## APPLICATIONS & MATERIALS

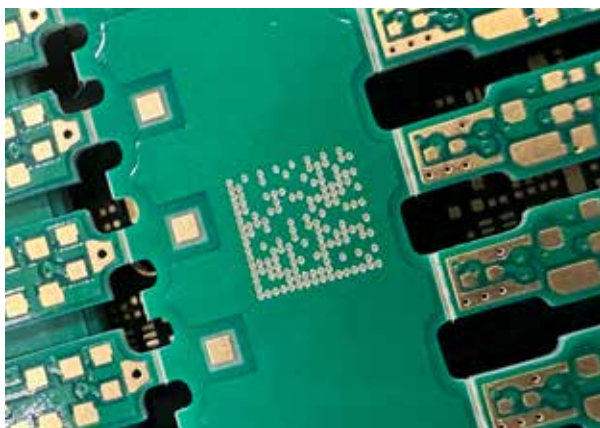

PCB marking



Wood marking

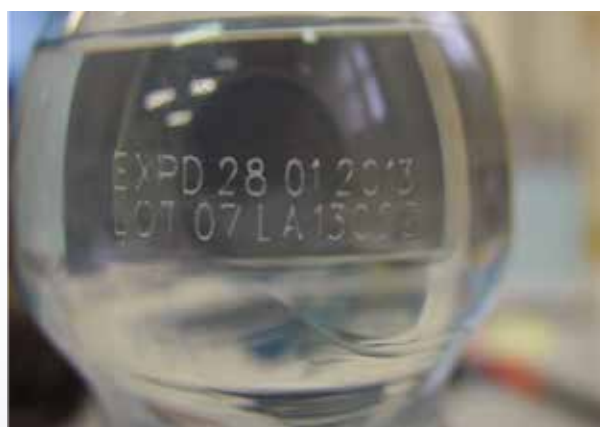

PET coding



Direct marking on cardboard

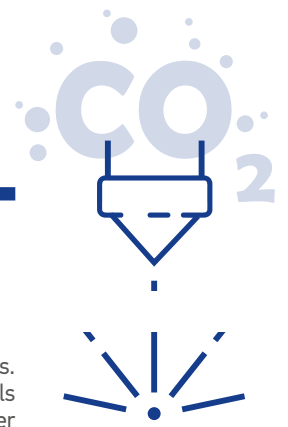

## EOX SERIES



EOX is a family of CO2 Laser Markers for laser coding and marking applications. EOX offers high-quality permanent marking on a wide range of materials like paper, carton, wood, plastics, painted or coated metals, and many other organic materials.

Combining excellent laser beam quality and an advanced control unit, EOX is suitable for accurate industrial traceability, branding and coding applications.

Based on the Embedded Marking Controller Platform (EMC), flexible “Stand Alone” or “Master –Slave” control modes and provides axis control as well as dedicated photocell / encoder ports for marking-on-the-fly (MOF).

Thanks to its low operating cost, long lifetime and minimal maintenance, EOX provides a reliable and clean technology for industrial marking and coding applications.

### Features & benefits

- Air-cooled, reduced footprint
- All-in-one design: scanning head, power & control electronics, marking controller, diagnostics and software suite
- Embedded visible aiming beam and focus beam for fast and easy focus setup and marking operation
- High resolution marking

### Main applications

- **General Marking**  
Label marking, paint stripping & coating removal, kiss-marking and perforating labels
- **Electronics**  
PCB marking and coding, ceramic component marking, alumina marking
- **Healthcare**  
Branding and coding containers
- **Food**  
Direct, high contrast marking on food (cheese, bread, eggs, fruits, vegetables ...)
- **Packaging**  
Marking coated paper, inked paperboards, film cutting and perforating

PARAMETER		EOX 10	EOX 30
Nominal average power	W	10	30
Wavelength	nm	10600	
Marking capabilities		Static, Rotary axis, On the fly (marking in motion)	
Integration		Up to 4 mechanical axis driving capabilities (stepper motor) Up to 10 digital inputs and 10 digital output fully programmable dedicated connectors Encoder and Photocell to 75mt/min and 12.000 pcs/hour	
Aiming & focus beam		Class II Semiconductor laser @ 635 nm	
Cooling system		Air cooled	
Resonator dimensions (HxWxD) & weight		180x180x598 mm - 17 kg	180x180x598 mm - 17 kg
Controller dimensions (HxWxD) & weight		---	88.5x430x335 mm - 9 kg
Power supply		100 – 240 VAC 50/60 Hz	
Operating temperature range	C°	15 to 35	

MODEL SELECTION AND ORDER INFORMATION		
ORDER NUMBER	MODEL	DESCRIPTION
985140021	EOX 6102-1241 CO2 Marker	EOX 10W@10600nm with F100 lens W10
985140022	EOX 6102-1541 CO2 Marker	EOX 10W@10600nm with F200 lens W10
985140023	EOX 6302-1541 CO2 Marker	EOX 30W@10600nm with F200 lens W10
985140024	EOX 6302-1241 CO2 Marker	EOX 30W@10600nm with F100 lens W10

# Laser Marking application map

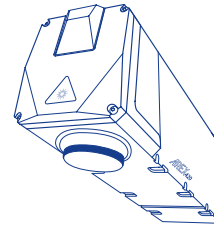

	units	AREX410	AREX420	AREX420MW	AREX430	AREX450
	W	10	20	20	30	50
	ns	100	100	4 - 250	100	100
	kW	10	10	12	10	10
	mJ	1	1	0,75	1	1
	nm	1070	1070	1070	1070	1070

## APPLICATIONS

<i>Annealing</i>		★	★★★	★★★	★★★	★★★
<i>Color Marking</i>		★	★	★★★	★	★
<i>Engraving</i>		★	★★	★	★★★	★★★
<i>Deep Engraving</i>		★	★	★	★★	★★★
<i>Surface Etching</i>		★★★	★★★	★★★	★★★	★★★
<i>Coating Ablation</i>		★★	★★★	★★★	★★★	★★★
<i>Coating Removal (Night &amp; Day)</i>		★	★★	★★★	★★	★★
<i>Bleaching</i>		★★★	★★★	★★★	★★★	★★
<i>Blackening</i>		★★★	★★★	★★★	★★★	★★
<i>Foaming</i>		★★★	★★	★★★	★★	★★
<i>Subsurface Engraving</i>		★	★	★★	★	★
<i>Texturing</i>		★★	★★★	★★★	★★	★★

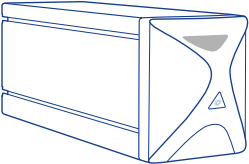
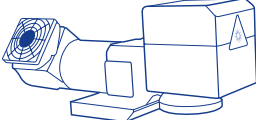
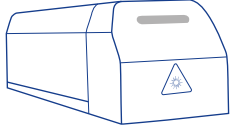
						
AREX401	UNIQ	VLASE IR 10	VLASE IR 20	VLASE UV 3	EOX 10	EOX 30
100	15	10	20	3	10	30
100	100	15	8	8		
10	7,5	32	65	14		
1	0,75	0,5	0,6	0,1		
1070	1070	1064	1064	355	10600	10600
★★	★★★	★★★	★★★	★	★	★
★	★	★	★★	★	★	★
★★★	★★★	★	★★	★	★★★	★★★
★★★	★★	★	★★	★	★★★	★★★
★★★	★★★	★★★	★★★	★★★	★	★
★★★	★★★	★★★	★★★	★★★	★	★
★	★★	★★★	★★★	★★	★	★
★★	★★★	★★★	★★★	★★	★	★
★★	★★★	★★	★★★	★★	★	★
★★	★★★	★★★	★★	★★	★	★
★	★	★	★★★	★	★	★
★★	★★★	★★★	★★★	★★★	★★	★★

# Laser Marking materials map

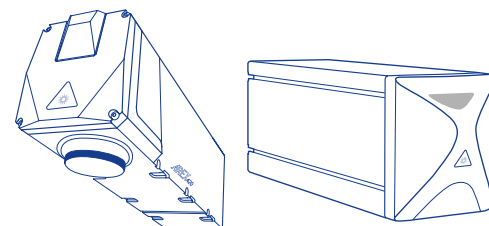

MATERIALS			AREX400 - UNIQ
<b>PLASTIC</b>			
<i>Acrylonitrile Butadiene Styrene</i>	ABS	Polylac Tairilac Terluran	★★★
<i>Epoxy</i>			★★★
<i>High-density polyethylene</i>	HDPE		★★★
<i>Polyoxymethylene</i>	POM		★★★
<i>Polyamide</i>	PA	Nylon®	★★★
	PA6	Arcony®l	
	PA66	Workmid®	
	PA66GF30	Vydyne®	
	PA66GF25	Technyl®	
	Natural PA66		
<i>Polybutylene terephthalate</i>	PBT		★★★
	PBT GF30		
<i>Polycarbonate</i>	PC	Lexan®	★★★
		Makrolon®	
<i>Polyether ether ketone</i>	PEEK		★★
<i>Polyester</i>	PES	Thermolite®, Polarguard®	★
<i>Polyethylene</i>	Natural PE	Mylar®	
<i>Polyethylene terephthalate</i>	PET	Mylar®	★
		Arnite®	
		Ertalyte®	
		Dacron®	
<i>Polyetherimide</i>	PEI-GF20		★★★
<i>Polyimide</i>	PI	Kapton®	★
<i>Polymethyl-methacrylate</i>	PMMA	Plexiglas®	★★
<i>Polyoxymethylene Black</i>	POM	Delrin®	★★★
<i>Polyoxymethylene White</i>			
<i>Polypropylene</i>	Natural PP		
<i>Polystyrene</i>	PS		★★★
<i>Polyurethane</i>	PUR		
<i>Polyvinil Chloride</i>	PVC		★★★
<i>Silicone</i>			★
<i>Styrene-acrylonitrile resin</i>	SAN	Tyrl®	★
<i>Urea</i>			
<b>CERAMICS</b>			
<i>Aluminum Oxide</i>	Al2O3	Alumina	★★
<i>Tungsten Carbide</i>	WC		★★
<i>Silicon Carbide</i>	SiSiC/SSiC	Rocar®	
<i>Silicon Nitride</i>	Si3N4		

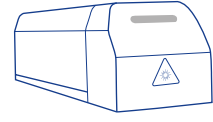
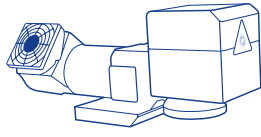

VLASE IR	VLASE UV	EOX
***		*
***		***
***		***
***	***	
**	***	
***		**
**	***	*
*	**	*
	**	**
***	***	
*		*
**	***	*
***		*
	**	
***		*
***	***	***
*	***	**
*	**	*
	**	**

MATERIALS			AREX400 - UNIQ	VLASE IR
<b>METALS</b>				
<i>Chromium</i>			***	***
<i>Cobalt</i>			***	***
<i>Copper</i>			**	**
<i>Gallium</i>			***	***
<i>Gold</i>			*	**
<i>Indium</i>			***	***
<i>Iron</i>			***	***
<i>Lead</i>			**	**
<i>Lithium</i>			***	***
<i>Magnesium</i>			***	***
<i>Molybdenum</i>			***	***
<i>Neodymium</i>			***	***
<i>Nickel</i>			***	***
<i>Palladium</i>			***	***
<i>Rodium</i>			***	***
<i>Samarium</i>			***	***
<i>Silicon</i>			**	***
<i>Silver</i>			*	**
<i>Tin</i>			***	***
<i>Tugsten</i>			***	***
<i>Vanadium</i>			***	***
<i>Zinc</i>			***	***
<i>Zirconium</i>			***	***
<b>METAL ALLOYS</b>				
<i>Aluminum Alloy</i>	1xxx- 8xxx	Anticorodal®, Ergal®,	***	***
	2xxx	Avional®, Duraluminum®	**	**
	1xxx- 8xxx	Zama®	**	**
<i>Brass</i>			***	***
<i>Stainless steel</i>			***	***
<i>Steel</i>			***	***
<i>Tungsten carbide</i>	WC		***	***
<i>Titanium alloy</i>	Ti-6Al-4V, Ti-6Al-7Nb		***	***
<b>OTHERS</b>				
<i>Glass</i>				
<i>Glass Pyrex</i>				
<i>Graphite</i>				
<i>Leather</i>				
<i>Paper</i>				
<i>Quartz</i>				
<i>Rubber</i>				
<i>Sapphire</i>				
<i>Stone</i>				
<i>Textiles</i>				



# Laser Marking accessories

## Remote start footswitch



Optional accessory dedicated to hands-free operations in manual loading machine and semi-automatic system

- Rugged, long life cast-iron FootSwitch
- Non-skid base and 3 meters cable.
- M12 connector to Laser Unit

<b>985350035</b>	REMOTE START FOOT SWITCH
------------------	--------------------------

## High resolution Displacement Measuring Sensor



Automatically measure target position displacement from optimal focus position, and correct laser head position acting directly to (optional) Z-axis  
simplified connectivity (dedicated "DEVICE PORT")  
complete kit, with mounting brackets and protective YAG filter.

<b>985350037</b>	MICROMETRIC DISTANCE SENSOR KIT AREX 400
<b>985350036</b>	MICROMETRIC DISTANCE SENSOR KIT AREX

## Protective lens cup



### PROTECTIVE LENS CUP

Easy to install, easy to replace, simplify preventive/periodic maintenance cleaning operation on F-theta lens and allow no-stop operations.

- Ensure complete IP64 protection
- Suitable for F160S and F254S lenses

<b>985350038</b>	M39 F-THETA PROTECTIVE CAP
------------------	----------------------------

## I/O Signal Conditioning Board



NEW Isolated Digital I/O Signal conditioning board with DIN-rail adapter.

- “Clean contacts” output
- “Clean Opto-isolated inputs”
- Pass-through Command Box Connector

**985330032**

IO INTERFACE

## Command Box DB25-to-free leads cable



3 meters cable DB25 Male-to-free-leads for simple and easy field connection to PLC or control system.

- Connect laser units, quickly and easily onsite without having to solder or crimp contacts.
- Individually labelled leads

**985350032**

SUB-D 25 PINS - TO FREE LEADS CABLE 3M

## Control box



Ready to use remote pendant for UNIQ AREX VLASE.

- 2 meters cable
- Key & enable selectors
- START STOP push-buttons
- READY, BUSY, END, ALARM led signals
- Available also for ULYXE series

**985330031**

CONTROL BOX STANDARD (AREX UNIQ VLASE)

# Accessories compatibility

## Fumes extractor



Twin filtration system prefilter + activated carbon.  
 → Entry-level, ultra-compact specialty laser fumes extractor  
 → Max air flow 180 m3/h  
 → Hose (50-50 mm, 4 m) and nozzle (50 mm) provided  
 → Features:  
 - START/STOP pushbutton  
 - FILTER CHANGE LED  
 → Dimensions 510x310x340 mm (HxDxW) – 23,5 kg  
 → Two versions: EU (230 VAC) or US (115 VAC)

Suitable for:  
 • Metal Marking  
 • Wood, paper marking  
 • Rubber, Plastic marking

<b>985340038</b>	LAS FUME EXTRACTOR BOFA BASIC 230VAC
<b>985340040</b>	LAS FUME EXTRACTOR BOFA BASIC 115VAC



Twin filtration system prefilter + activated carbon.  
 → High-capacity, smart, specialty laser fumes extractor  
 → Max air flow 380 m3/h  
 → Hose (75-50 mm, 4 m) and nozzle (50 mm) provided  
 → Features:  
 - Digital START/STOP signal  
 - Digital FILTER CHANGE signal  
 Start OVERRIDE  
 → Dimensions 970x500x447 mm (HxDxW) – 65 kg  
 → Multi-supply: 90 – 257 VAC

Suitable for:  
 • Metal Marking  
 • Wood, paper marking  
 • Rubber, Plastic marking

<b>985340039</b>	LAS FUME EXTRACTOR BOFA PRO 90-257VAC
------------------	---------------------------------------

MODEL	DESCRIPTION	AREX400	VLASE	UNIQ
93ACC1918	MARVIS SW LICENCE	✓	✓	✓
93ACC1919	PROFINET LICENSE FOR LIGHTER	✓	✓	✓
93ACC0372	MARVIS BRACKETS FOR S&M&L FTHETA	✓		
93ACC1915	MARVIS MOUNTING BRACKET FOR UNIQ & M300N			✓
985350035	REMOTE START FOOT SWITCH	✓	✓	✓
985330032	RELE INTERFACE	✓	✓	✓
985330031	CONTROL BOX STANDARD	✓	✓	✓
985350038	M39 F-THETA PROTECTIVE CAP	✓ (only models AREX XXX-3XX and AREX XXX-6XX)		
93ACC0371	F-THETA PROTECTIVE CAP FOR M LENS	✓ (only models AREX 10C-M65 and AREX 10C-N65)		
985350037	MICROMETRIC DISTANCE SENSOR KIT AREX 400	✓		
985350036	MICROMETRIC DISTANCE SENSOR KIT AREX/VLASE/UNIQ		✓	✓
985350039	RACK HANDLES AREX 400	✓		
985350032	DB25-TO-FREE LEADS CABLE	✓	✓	✓
985340038	LAS FUME EXTRACTOR BOFA BASIC 230VAC	✓	✓	✓
985340039	LAS FUME EXTRACTOR BOFA PRO 90-257VAC	✓	✓	✓
985340040	LAS FUME EXTRACTOR BOFA BASIC 115VAC	✓	✓	✓

# Lens specification

## F-THETA LENS & ACCESSORIES

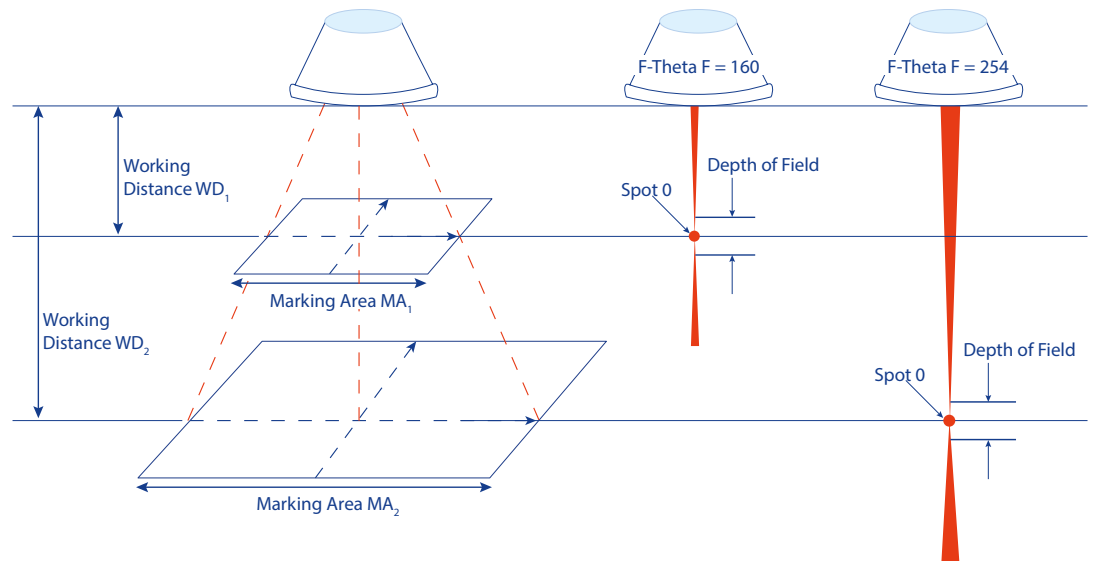

### 1064 nm F-THETA LENS & ADAPTER

F-THETA LENS	WORKING AREA	WORKING DISTANCE	SPOT Ø (Typ)	LENS THREAD	LASER PRODUCT		
MODEL	[WA] mm <sup>2</sup>	[WD] mm	µm	mm	AREX 410 AREX 420 AREX 420MW UniQ	AREX 401 AREX 430 AREX 450	VLASE IR
F100L	50 x 50	99	~ 40	M85x1,0	✓	X	X
F 160S	100 x 100	183	~ 60	M39x1.0	✓	X	✓
F 254S	140 x 140	280	~ 100	M39x1.0	✓	X	✓
F 160L	110 x 110	176	~ 60	M85x1,0	*	✓ (100 x 100)	✓
F 254L	180 x 180	296	~ 100	M85x1.0	*	✓	✓
F 330L	220 x 220	388	~ 130	M85x1.0	✓	✓ (210 x 210)	✓
F 420L	285 x 285	494	~ 160	M85x1.0	✓	✓	✓

\* not available on all product configurations

### 355 nm F-THETA LENS

F-THETA LENS	WORKING AREA	WORKING DISTANCE	SPOT Ø (Typ)	LENS THREAD	VLASE-UV
MODEL	[WA] mm <sup>2</sup>	[WD] mm	µm	mm	
F 103T**	60 x 60	135	~ 30	M85x1.0	✓
F 160L	110 x 110	197	~ 35	M85x1.0	✓

\*\*Telecentric F-theta Lens

### 10.600 nm ZINC SELENIDE CO2 F-THETA LENS

F-THETA LENS	WORKING AREA	WORKING DISTANCE	SPOT Ø (Typ)	LENS THREAD	LASER PRODUCT	
MODEL	[WA] mm <sup>2</sup>	[WD] mm	µm	mm	EOX-10	EOX-30
F 100	70 x 70	100	approx. 230	Ø 48	✓	✓
F 200	140 x 140	200	approx. 460	Ø 48	✓	✓

When handling optics, one should always wear gloves. This is especially true when working with zinc selenide, as it is a hazardous material. For your safety, please follow all proper precautions, including wearing gloves when handling these lenses and thoroughly washing your hands afterward.

